

Series K Pneumatic Switch Mechanism

Installation and Operating Manual

*Non-Bleed
Switch For
Liquid Level
Switches*



Read this Manual Before Installing

This manual provides information on the Series K Pneumatic Switch Mechanism. It is important that all instructions are read carefully and followed in sequence. Detailed installation and hook-up instructions are included in this manual.

Conventions Used in this Manual

Certain conventions are used in this manual to convey specific types of information. General technical material, support data, and safety information are presented in narrative form. The following styles are used for notes, cautions, and warnings.

Notes

Notes contain information that augments or clarifies an operating step. Notes do not normally contain actions. They follow the procedural steps to which they refer.

Cautions

Cautions alert the technician to special conditions that could injure personnel, damage equipment, or reduce a component's mechanical integrity. Cautions are also used to alert the technician to unsafe practices or the need for special protective equipment or specific materials. In this manual, a caution box indicates a potentially hazardous situation which, if not avoided, may result in minor or moderate injury.

Warnings

Warnings identify potentially dangerous situations or serious hazards. In this manual, a warning indicates an imminently hazardous situation which, if not avoided, could result in serious injury or death.

Safety Messages

Follow all standard industry procedures for servicing electrical equipment when working with or around high voltage. Always shut off the power supply before touching any components.

Low Voltage Directive

For use in Installations Category II, Pollution Degree 2. If equipment is used in a manner not specified by the manufacturer, protection provided by equipment may be impaired.

Notice of Copyright, and Limitations

Copyright © 2010 Magnetrol International, Incorporated. All rights reserved.

Magnetrol reserves the right to make changes to the product described in this manual at any time without notice. Magnetrol makes no warranty with respect to the accuracy of the information in this manual.

Warranty

All Magnetrol mechanical level and flow controls are warranted free of defects in materials or workmanship for five full years from the date of original factory shipment.

If returned within the warranty period; and, upon factory inspection of the control, the cause of the claim is determined to be covered under the warranty; then, Magnetrol will repair or replace the control at no cost to the purchaser (or owner) other than transportation.

Magnetrol shall not be liable for misapplication, labor claims, direct or consequential damage or expense arising from the installation or use of equipment. There are no other warranties expressed or implied, except special written warranties covering some Magnetrol products.

Quality Assurance

The quality assurance system in place at Magnetrol guarantees the highest level of quality throughout the company. Magnetrol is committed to providing full customer satisfaction both in quality products and quality service.

Magnetrol's quality assurance system is registered to ISO 9001 affirming its commitment to known international quality standards providing the strongest assurance of product/service quality available.



1.0 Description

The Series K is a non-bleed pneumatic switch. It incorporates a three-way pneumatic valve assembly, actuated by a magnet swing carriage. Mechanisms are available as an option for most Magnetrol liquid level controls.

2.0 Technology

Magnetic force and the lever mechanism transmit movement from the pressure vessel to the pneumatic valve.

Figure 1 shows the position of the attraction sleeve and magnet when the liquid level is such that the attraction sleeve is below the field of the magnet. In this position, the flapper has been drawn away from the valve rod, permitting the inlet air or gas to flow to a pneumatic operator. Inlet air pressure against the ball allows the ball to seal off the exhaust outlet.

Figure 2 shows the position of the attraction sleeve and the magnet when the liquid level has risen, causing the attraction sleeve to attract the magnet against the enclosing tube. In this position, the flapper actuates the air valve, closing the supply inlet and opening the exhaust port, which reduces the pressure in the operator to atmospheric. This action, “close” on high, is reversible to “open” on high with two simple adjustments (refer to page 4).

NOTE: In order to protect the switch assembly from contaminants, filtered and dried gas/air supply is recommended.

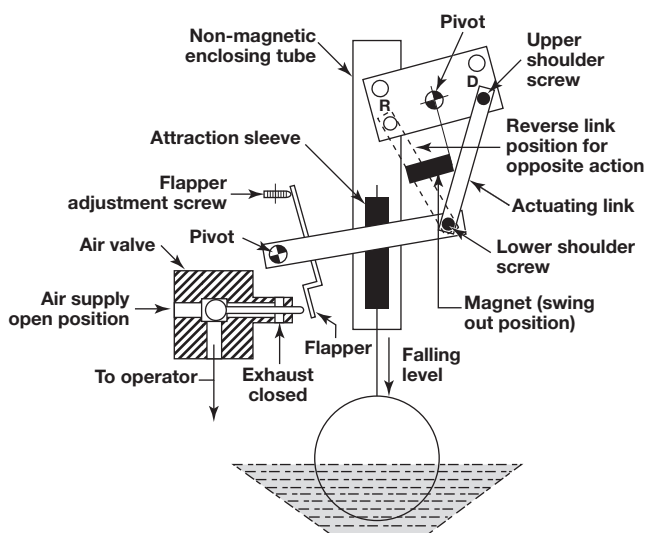

Figure 1
Attraction sleeve below field of magnet

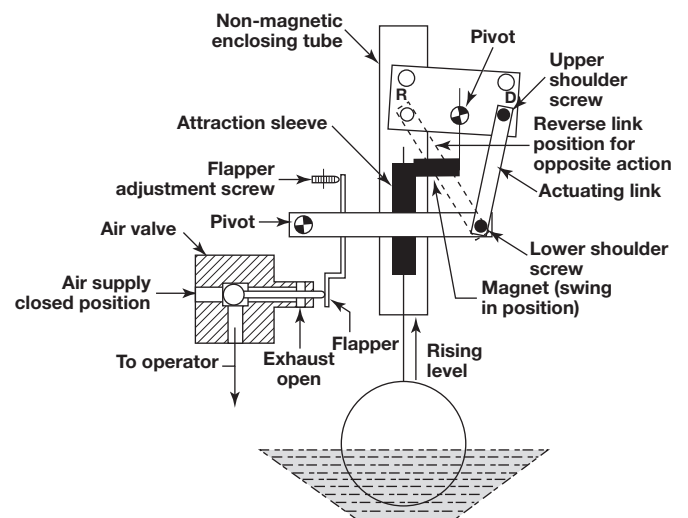

Figure 2
Attraction sleeve in field of magnet

3.0 Reversing Pilot Action

All Series K Pneumatic Switch Mechanisms are shipped from the factory in the direct (close) position at high level. They can be field modified for the reverse (open) position by following the steps below:

1. The action can be reversed by first removing the upper shoulder screw from the actuator link and moving it from the direct (D) position to the reverse (R); refer to Figure 3.
2. Loosen the screw that positions the spring bracket and move it from the direct (D) position to the reverse (R) position; refer to Figure 4.
3. Fasten screw securely.

The switch is now setup for reverse action.

4.0 Locating Air Line Connection

Caution: Instrument is designed for dry air/gas service.

The housing base may be rotated a full 360° for your convenience in connecting the air supply.

1. Loosen both the special locking screw above the enclosing tube nut and the frame screw. Refer to Figure 3.
2. Rotate the entire base to the desired position.
3. Tighten both the locking screw and the frame screw.

4.0.1 Remove complete mechanism

1. Disconnect air line from air line adapter.
2. Loosen both the special locking screw, above the enclosing tube nut, and the frame screw approximately 3 to 4 turns. Refer to Figure 3.
3. Lift the entire base straight up and off the enclosing tube.

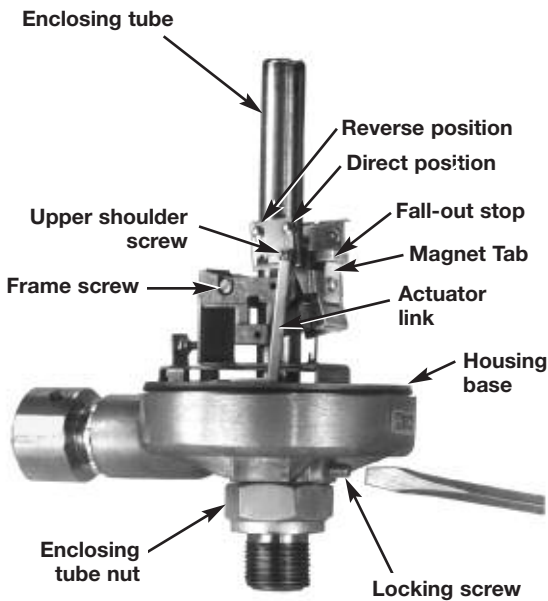

Figure 3

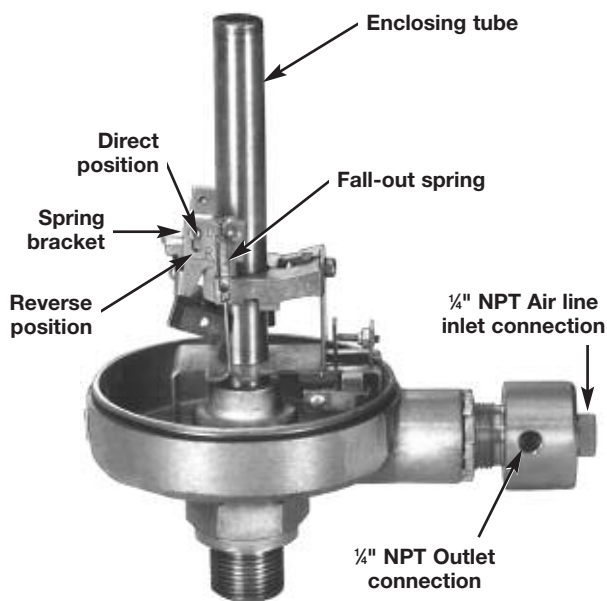

Figure 4

5.0 Preventive Maintenance

5.0.1 Nozzle cleaning

To clean the nozzle, follow the steps below:

1. Unscrew and remove the adapter. Refer to Figure 5.

Caution: Do not lose the ball which will drop out when the adapter is removed.

2. The ball and actuating rod will now fall out when the switch is tipped.
3. Unscrew the socket set screw with a $\frac{1}{16}$ " Allen wrench. This will prevent damage to the flapper when performing step 4.
4. Insert a $\frac{1}{16}$ " diameter wire into the nozzle from the air line connection side. Refer to Figure 6. The wire may be moved back and forth to clean the opening of any accumulated matter.
5. Reassemble the actuating rod, ball, and adapter; insert into nozzle. Refer to Figure 5.
6. Securely tighten the air line adapter.
7. Readjust the flapper to its original position; refer to Nozzle Flapper Readjustment procedure.

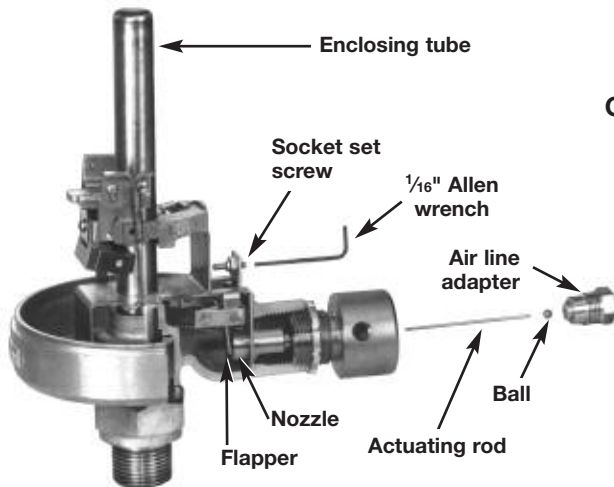

Figure 5

5.0.2 Nozzle flapper readjustment

1. Connect an air line to the adapter.
2. Pressurize the air line.
3. Adjust the flapper with the socket set screw for the desired action:

Direct Action

- A. Hold the magnet against the enclosing tube.
- B. Adjust the socket set screw with a $\frac{1}{16}$ " Allen wrench until the air flow stops, plus an extra one-eighth turn.

Reverse Action

- A. Hold the magnet tab against the fall out stop. Refer to Figure 3.
 - B. Adjust the socket set screw with a $\frac{1}{16}$ " Allen wrench until the air flow stops.
4. Manually actuate the switch under pressure to assure its correct actuation. The unit is now ready for service.
 5. Operate control at normal process conditions to verify adjustments.

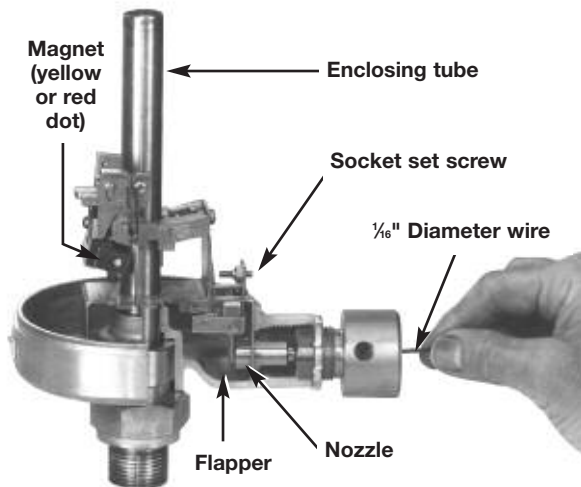

Figure 6

6.0 Replacement Parts

6.1 K Series pneumatic switch

Replacement parts for K Series Pneumatic Switch Mechanisms are available as an assembly only. Switch mechanism consists of entire pneumatic assembly mounted in the switch housing base. See figure 7 below. When ordering an assembly, be certain to specify:

1. The model number of the level control in which the switch was installed.
2. The serial number of the level control in which the switch was installed. Refer to nameplate attached to control.

Caution: When ordering replacement switch mechanisms, be certain to determine color dot on magnet. Never replace a mechanism having a red dot magnet with one having a yellow dot magnet, and vice versa.

Switch Code	Magnet	Part Number
KOE	Yellow	89-7501-023
KOF	Yellow	89-7501-023
KOG	Red	89-7501-024
KOH	Red	89-7501-024
KPE	Yellow	89-7501-025
KPF	Yellow	89-7501-025

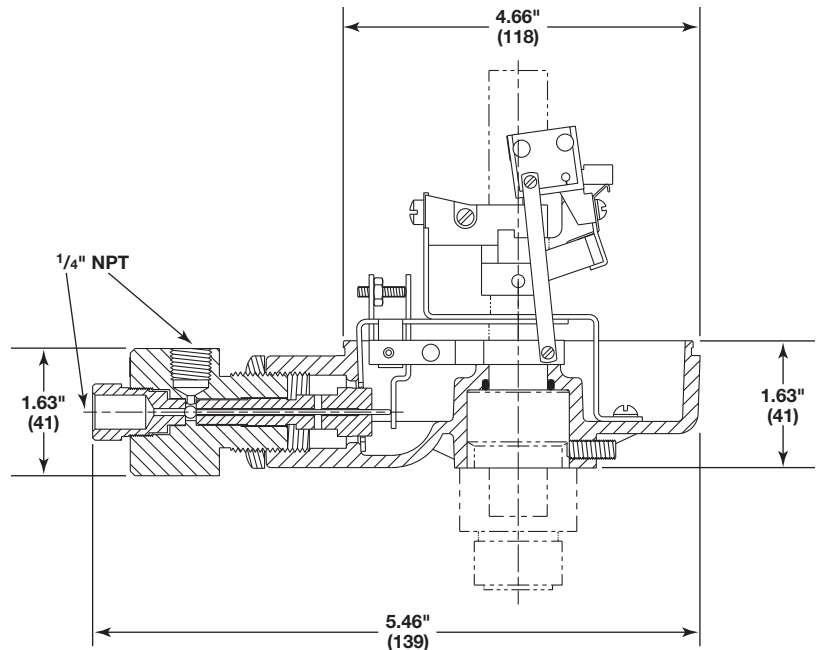

Figure 7

6.2 Switch housing replacement assembly

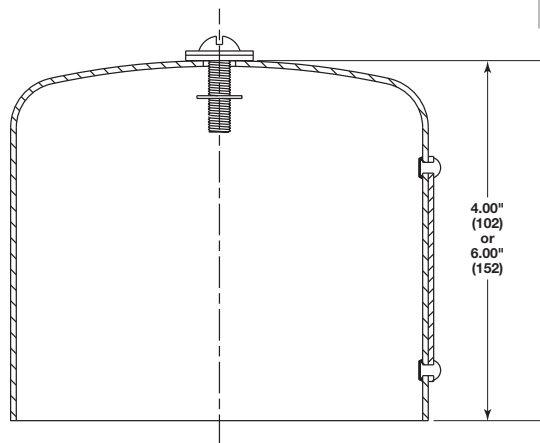

Figure 8
Carbon steel housing assembly

Standard carbon steel housing replacement assemblies are designed for general purpose indoor use installations requiring protection against entrance of dust, water, lint and fiber/oil. Refer to Figure 8.

Description		Replacement Kit Part Number
		Blue Cover
Standard housing cover	Short 4" (102 mm)	89-6509-003 ①
	Tall 6" (152 mm)	89-6510-003 ①
Cover assembly hardware		89-6508-001

① Includes assembly hardware kit 89-6508-001.

7.0 "K" Switch Specifications

Supply Pressure:	40 psi Max. or 100 psi Max.
Airline Connections:	¼" NPT
Maximum Leakage Rate:	0.5 SCFH
Maximum Airflow:	
100 psi Max. supply pressure	1.1 SCFM
40 psi Max. supply pressure	0.7 SCFM
Maximum Process Temp.:	+400° F
Housing Protection:	General Purpose/NEMA 1/IP53
Housing Material:	Rolled steel/Cast aluminum
Switch Mechanism Material:	Stainless steel

8.0 Switch Codes

SWITCH MECHANISM AND ENCLOSURE

Switch Code	Maximum Supply		Magnet Dot	For use with		Cover Height		
				E-tube Wall				
	PSIG	Bar		Inches	(mm)	Attraction Sleeve	Inches	(mm)
KOG	40	3	Red	.035	.9	Standard	4	102
KOH	40	3	Red	.035	.9	Standard	6	152
KOE	100	7	Yellow	.035	.9	Sheathed	4	102
KOF	100	7	Yellow	.065	1.7	Standard	6	152
KPE	100	7	Yellow	.065	1.7	Sheathed	4	102
KPF	100	7	Yellow	.065	1.7	Sheathed	6	152

Maximum leakage rate is .5 SCFH at maximum supply pressure. Maximum process temperature is +400° F (+209° C).

Example Model Number:

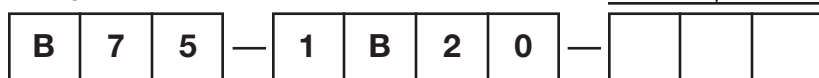

Service Policy

Owners of Magnetrol may request the return of a control or any part of a control for complete rebuilding or replacement. They will be rebuilt or replaced promptly. Controls returned under our service policy must be returned by Prepaid transportation. Magnetrol will repair or replace the control at no cost to the purchaser (or owner) other than transportation if:

1. Returned within the warranty period; and
2. The factory inspection finds the cause of the claim to be covered under the warranty.

If the trouble is the result of conditions beyond our control; or, is NOT covered by the warranty, there will be charges for labor and the parts required to rebuild or replace the equipment.

In some cases it may be expedient to ship replacement parts; or, in extreme cases a complete new control, to replace the original equipment before it is returned. If this is desired, notify the factory of both the model and serial numbers of the control to be replaced. In such cases, credit for the materials returned will be determined on the basis of the applicability of our warranty.

No claims for misapplication, labor, direct or consequential damage will be allowed.

Return Material Procedure

So that we may efficiently process any materials that are returned, it is essential that a "Return Material Authorization" (RMA) number be obtained from the factory, prior to the material's return. This is available through Magnetrol's local representative or by contacting the factory. Please supply the following information:

1. Company Name
2. Description of Material
3. Serial Number
4. Reason for Return
5. Application

Any unit that was used in a process must be properly cleaned in accordance with OSHA standards, before it is returned to the factory.

A Material Safety Data Sheet (MSDS) must accompany material that was used in any media.

All shipments returned to the factory must be by prepaid transportation.

All replacements will be shipped F.O.B. factory.

